



P-19



PRELIMINARY SCHEDULE P-19 (2018-2019)

1. Triangle Loop, $\frac{1}{2}$ rolls horizontal, 2 of 4 point rolls on 45's
2. Tear drop, opposite half rolls 45, 4 of 8 point roll down
3. Cuban 8 with snaps
4. Half Square loop, half roll
5. Reverse Cobra, full roll, 2 of 4 point roll
6. Two turn spin
7. Figure 9 with half roll
8. Push-Push-Push Humpty – 2 of 4 point up, **Opposite** half rolls down
Option – $\frac{1}{4}$ roll up - half roll, quarter roll opposite down
9. Full roll - Stall turn, 3 of 4 point up, $\frac{3}{4}$ roll down, **Exit Inverted**
10. Half reverse Cuban, full roll
11. Knife Edge, 1-1/4 roll entry/exit, **exit upright**
12. Immelmann
13. Loop, half rolls integrated top 180
14. Half square loop on corner, half roll second leg
15. Double Key, full rolls vertical, $\frac{1}{2}$ rolls 45's
16. Half Cuban 8 – 2 of 4 point roll down
17. Square Loop – $\frac{1}{2}$ rolls all sides

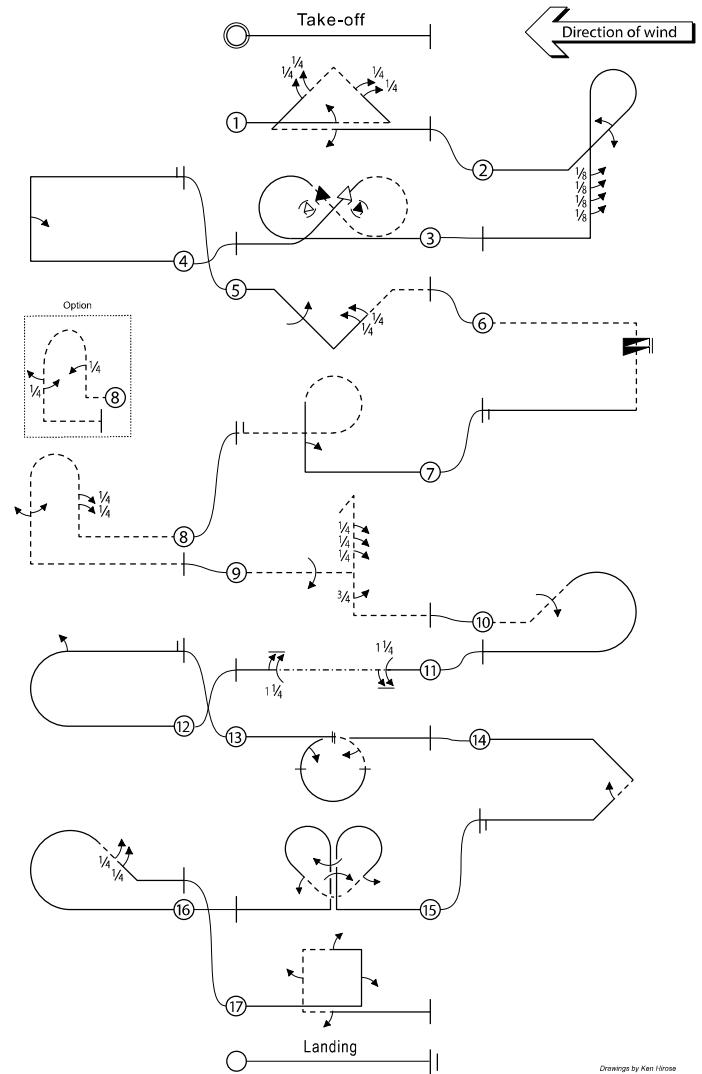

Drawings by Ken Ffross
Oct. 2014